

# gForce LCS™

## Large Ceiling System



R-410A and R-407C | 6, 8, 10 and 13 ton



# Model Number Identification

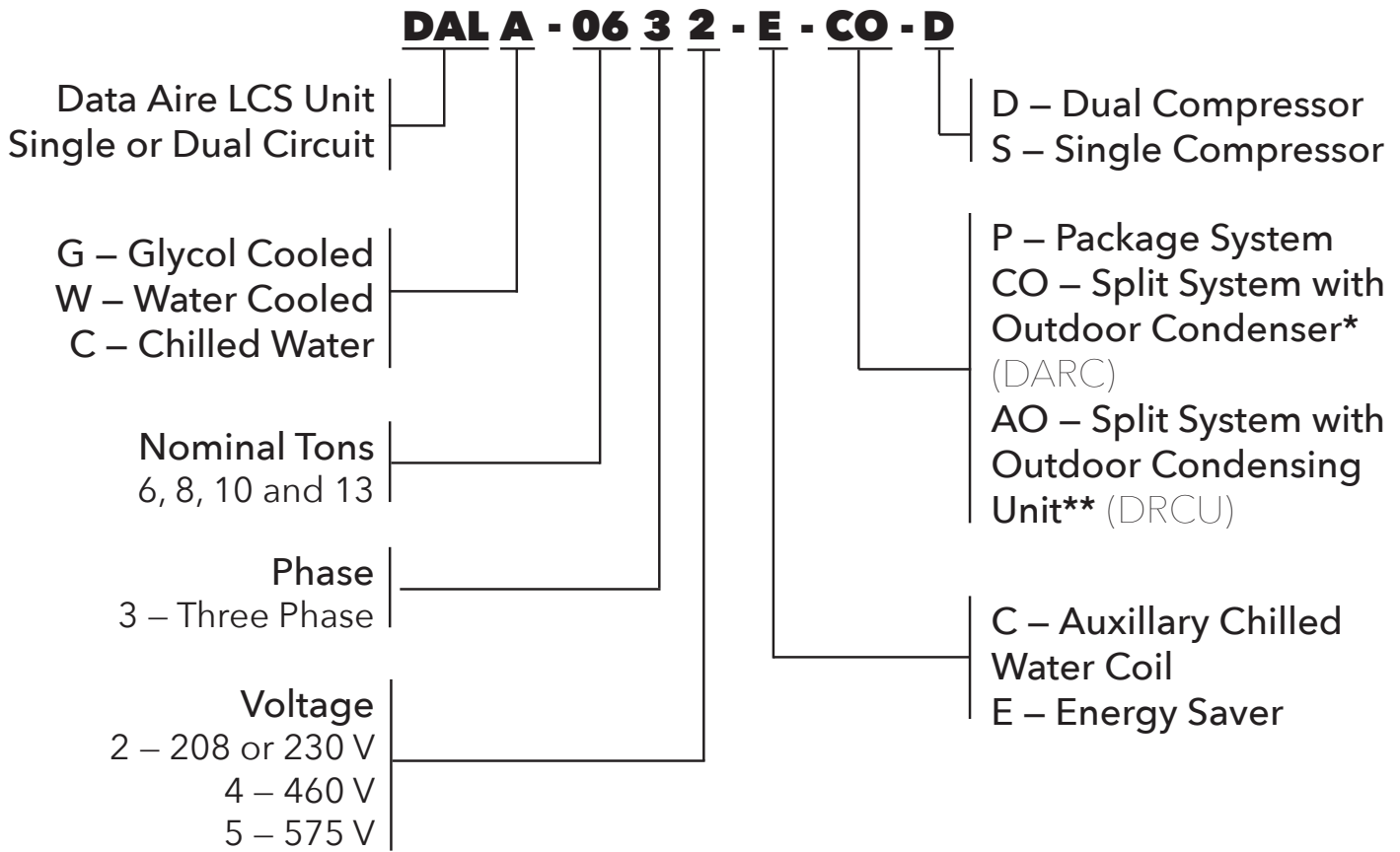

\*CONDENSER - Condenser coil only, no compressor

\*\*CONDENSING UNIT - Condenser coil and compressor



Building on more than 50 years of experience, Data Aire produces innovative solutions to meet the developing demands of critical spaces. We are a solutions-driven organization with a passion for finding creative answers by working with our customers through a consultative process.

Known for products that are designed utilizing high levels of technology, Data Aire engineers are experienced visionaries who adapt processes and design proprietary unit enhancements which reflect the constant needs of today's mission critical spaces.

Data Aire combines extensive expertise in control logic with world-class manufacturing capability recognized by key international quality certifications. For those seeking reliable, scalable, customized technology, we provide the solutions of choice. Our precision air control equipment and intelligent energy management technology serve customers in diverse applications worldwide.

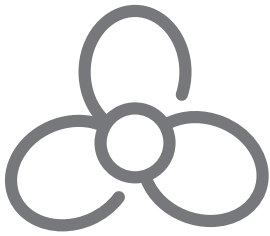

## MISSION CRITICAL COOLING

LCS is a precision environmental control system that brings a standard of reliable performance required by today's market demands: small and medium size data centers, telecommunication sites, or where floor space is not available and larger tonnage units are required. Designed for ducted above ceiling applications, the LCS may be ordered as an air or water/glycol cooled direct expansion unit with single or dual compressors. Chilled water units are also available. Each LCS unit is factory run tested and put through a rigorous quality control procedure.



## DATA AIRE DELIVERS

Standard lead time for a standard unit is 30 days from date of order. With an optional premium "quick ship" units can be expedited to ship in as little as one week. All units are built to your specific order and specification. Not only does Data Aire deliver standard products in short lead times and our consultative process helps you meet your specific requirements.

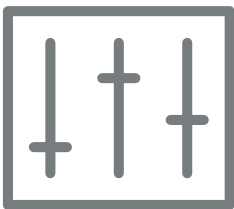

## CONTROL

The heart of the LCS is the Mini dap<sup>TM</sup>4, a microprocessor based controller designed for precision environmental control. The Mini dap4 not only controls and monitors temperature, humidity, airflow, and cleanliness, it provides alarm history and automatic self-tests. All information is provided on a liquid crystal display (LCD).



### IMPROVED PERFORMANCE AND REDUCED MAINTENANCE

Backward curved fans discharge air radially allowing for uniform static pressure across the raised floor. Traditional forward curved fans prohibit optimal airflow through the raised floor close to the CRAC. One of the key features of backward curved fans, commonly referred to as plug fans, is that the motor and fan are integrated into a single unit. This eliminates the need for monthly maintenance, belt replacement and all belt dust.

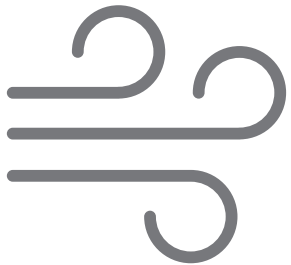

### IMPROVED AIRFLOW DESIGN

The increased capacity of the gForce internal cabinet allows for less restrictive airflow. When additional options are added to smaller cabinets, the static pressure within the unit increases, making airflow more difficult. The advanced design of the bigger interior and the product's quality construction ensures the highest level of efficiency in a precision air system.



### ENVIRONMENTALLY RESPONSIBLE

The R-407C or R-410A refrigerants comply with the requirements of the Montreal Protocol which called for the phase out of refrigerants that deplete the ozone layer.

# Design Features

## FRAME AND CABINET

The heliarc welded tubular steel frame provides for maximum strength and ease of access. Side and front panels can be easily opened and removed with quarter-turn fasteners allowing full access to all unit components. All panels include one inch thick, 1-1/2 pound density insulation for protection and sound attenuation.

## COIL SECTION

Designed for draw through application, the computer selected coil offers greater efficiency in the cooling and dehumidification process. Air bypass is provided to prevent saturated air from being introduced into the controlled space. The coil section is provided with a stainless steel drain pan.

## FAN SECTION

The centrifugal, forward curved, double width, double inlet blower configuration is engineered for quiet reliable operation. The belt driven variable pitch drive section provides adjustable air flow capability to match load requirements of the controlled space. The draw through design insures even air distribution across the coil and bypass, low internal cabinet losses, and static sealing of the filter section. Motors are mounted on an adjustable slide base and have internal overload protection.

## ELECTRIC REHEAT

Two stage electric reheat is standard. Low-watt density finned tubular sheathed coils are constructed of stainless steel and sized to maintain room dry bulb conditions during a call for dehumidification. Low-watt density coils eliminate ionization associated with open air electric resistance heating.

## FILTER SECTION

Units are provided with 4 inch deep pleated design, MERV 8. The filter section is an integral part of the system and is accessible from either side.

## REFRIGERATION CIRCUIT

LCS is available with either a single or dual refrigeration circuit. The refrigeration circuit includes a hermetic scroll compressor. These durable, heavy duty, fully welded compressors have no gaskets or seals, eliminating the possibility of refrigerant or oil leaking into the controlled space or environment. Scroll compressors also bring a combination of reliability, efficiency, and improved system sound performance. The refrigeration circuit includes built-in compressor overload protection, crankcase heater, filter drier, sight-glass, adjustable expansion valve with external equalizer, low pressure override timer (air cooled units), manual reset high pressure control, and compressor short cycle timer.

Water/glycol cooled units include a plate fin condenser sized to provide the required capacity for heat rejection with minimum water/glycol flow and low total pressure drop. Head pressure regulating valves control the condensing temperature and maintain required capacity at various water/glycol flow rates and temperatures.

### AIR COOLED WITH REMOTE OUTDOOR CONDENSER

A wide range of outdoor condensers are available. Condensers are manufactured by Data Aire and sized to meet heat rejection and ambient conditions as required. The industrial duty design includes galvanized corrosion resistant housing, aluminum finned copper tube coils, coated fan guards, energy efficient thermally protected direct drive motors, and variable fan speed control on lead motor for proper control down to -20 F ambient temperatures. Additional fan motors are controlled with ambient thermostats.

### AIR COOLED WITH OUTDOOR CONDENSING UNIT

When compressors are required to be out of the controlled space, LCS is available with a remote outdoor condensing unit. The condensing unit includes hermetic scroll compressor(s) with built-in overload protection, crankcase heater, filter drier, sight-glass, and condenser coil. The coil is constructed with copper tubes and aluminum fins. The housing is galvanized steel with vertical air discharge. The condenser fan motor is variable speed type for head pressure control down to -20° F ambient temperatures. Additional fan motors are controlled by ambient fan thermostats.

### WATER/GLYCOL COOLED WITH REMOTE OUTDOOR DRY COOLER

Remote outdoor dry coolers are available in a variety of sizes. Each dry cooler includes aluminum corrosion resistant housing, aluminum finned copper tube coil, coated fan guards, surge tank, pump contactor, and energy efficient thermally protected direct drive motors. Dry coolers with multiple motors have cycling control.

## CHILLED WATER SYSTEMS

Chilled water systems include all the same features of the LCS product line. Designed for draw through application, the computer selected coil offers greater efficiency in the cooling and dehumidification process. Air bypass is provided to prevent saturated air from being introduced into the controlled space. Chilled water flow is controlled by a 3-way chilled water valve for accurate and economical temperature control and dehumidification.

# Intelligent Controls

## SMART SYSTEM CONTROLS FOR MISSION CRITICAL ENVIRONMENTS

Incorporating advances based on years of control-logic experience, Data Aire system control products offer maximum operational flexibility and growth potential. From a versatile microprocessor controller or a dependable relay autochangeover unit, to accessories that help prevent hot spots in rack installations and compensate for short-term power outages, Data Aire technology keeps you in command.

The gForce systems come equipped with dap4 touch for the dap4 control panel. dap4 supports the following network protocols for integration with a Building Management System (BMS) for Computer Room Air Conditioning (CRAC) system monitoring and control: Modbus RTU, TCP/IP, SNMP V1 or V2, BACnet IP or MS/TP and LonTalk SNVT. Building Management System Interface: Unit(s) shall be furnished with an optional interface card to communicate directly with the Building Automation System (BAS) through a RS-485, Ethernet or LonTalk port. All alarms, set points, and operating parameters that are accessible from the unit mounted control panel shall also be made available through the BAS.

## CONTROLS

### AUTOMATIC CONTROL FUNCTIONS

- Humidity Anticipation
- Auxiliary Chilled Water Operation\*
- Sequential Load Activation
- Start Time Delay
- Automatic Reheat Element Rotation
- Temperature Anticipation
- Energy Saver (Glycol Operation)\*
- Hot Water Coil Flush Cycle\*
- Dehumidification Lockout
- Chilled Water Coil Flush Cycle\*
- Energy Saver Coil Flush Cycle\*
- Selectable Water Under Floor Alarm Action
- Compressor Short Cycle

### CONDITION AND DATA ROUTINELY DISPLAYED

- Current Date and Time
- Unit Status
- Temperature Setpoint
- Humidity Setpoint
- Current Temperature
- Cooling 1, 2, 3, 4\*
- Current Humidity
- Dehumidification
- Humidification
- Current Fan Speed\*
- Reheat Stages
- Discharge Temperature\*

### SWITCHING AND CONTROL FUNCTIONS

- System On/Off/Esc Button
- Menu Selection Buttons
- Menu Exit Button
- Select Buttons
- Alarm Silence Button
- Program Set Button
- Manual Override for:
  - Cool 1, Cool 2, Heat 1, Humidification, CW Valve and Fan Speed

## ALARMS

- High Temperature Warning
- Low Temperature Warning
- Low Pressure Compressor 1
- High Pressure Compressor 1
- Dirty Filter
- Firestat Tripped
- Temperature Sensor Error
- No Water Flow\*
- Fan Motor Overload\*

- High Humidity Warning
- Low Humidity Warning
- Low Pressure Compressor 2
- High Pressure Compressor 2
- Under Floor Water Detection
- Compressor Short Cycle
- Humidity Sensor Error
- Smoke Detector\*
- Standby Pump On\*

- Local Alarm
- Manual Override
- Humidifier Problem
- Custom Message\*
- Power Failure Restart
- Maintenance Required
- Discharge Sensor Error\*
- High Condensate Water Level\*
- Person to Contact on Alarm\*



## HISTORICAL DATA

High Temperature Last 24 Hours  
High Humidity Last 24 Hours  
Alarm History (Last 100 Alarms)  
Equipment Runtimes for:  
Blower, Compressor 1, Compressor 2, Reheat 1, 2, 3, Dehumidification,  
Energy Saver\*, Humidifier, Condenser and Chilled Water

Low Temperature Last 24 Hours  
Low Humidity Last 24 Hours  
Hourly Average of Duty

## PROGRAMMABLE FUNCTIONS

Temperature Setpoint	Temperature Deadband	Fan Control Mode
System Start Delay	Low Temperature Alarm Limit	Humidity Deadband
Humidity Setpoint	High Humidity Alarm Limit	Low Humidity Alarm Limit
Define Password	Reset Equipment Runtimes	Audio Alarm Mode
Compressor Short Cycle Alarm	Humidity Anticipation	Compressors(s)
Analog Module Sensor Setup*	Calibrate Temperature Sensor	Temperature Scale
High Temperature Alarm Limit	Fan Speed Settings	Delay for Optional Alarm 1, 2, 3, 4
Firestat Temperature Alarm Limit	Manual Diagnosis	Remote Alarm 1, 2, 3, 4 Selection
Calibrate Discharge Air Sensor*	Person to contact on Alarm	Compressor Lead/Lag Sequence
Dehumidification Mode	Humidifier Autoflush Timer*	Power Problem or Restart Mode
Scheduled Normal Maintenance	Reheat Stages	Water Valve Mode
Calibrate Humidity	Humidifier	Network Protocol
Compressor Supplements to Energy Saver*		
Low Discharge Temperature Alarm Limit*		
Calibrate Chilled Water Temperature Sensor*		

## ACCESSORIES

RackSense 32  
dap4 Smart Power Capacitor  
dap4 Power Meter

\* Optional: Some of the programmable selections, displays or alarms may require additional components or sensors.

## Energy Saver Coil

The Data Aire Energy Saver Coil is built into the system to provide total required capacity. Whenever the incoming water/glycol temperature is below 45° F/7.2° C, Energy Saver cooling is available. Energy Saver mode operates in the following range: Return air setpoint plus deadband plus two degrees. The Energy Saver will operate providing there is a need for cooling. The valve will open at setpoint plus deadband. The valve will modulate as long as the space is between setpoint plus deadband plus 2 degrees. If the temperature falls below the deadband minus setpoint, the valve will close and the space is considered satisfied. While still in Energy Saver with the valve modulating, if the temperature goes beyond setpoint plus deadband plus 2 degrees the Energy Saver valve will close and DX cooling will begin.

The Energy Saver Coil includes the next size motor, 3-way pressure control valve on condenser water circuit, and a 3-way valve on the Energy Saver coil. Common piping for coil and condenser is provided.

## Auxiliary Chilled Water Coil

Where an existing chilled water loop is available, units can be fitted with an auxiliary chilled water coil. Units will operate using the chilled water for cooling. Upon a loss of water flow or an increase in room temperature the system will bring on compressor (DX) cooling. The Auxiliary Chilled Water Coil includes the next size motor. Separate piping is provided for the chilled water coil and refrigeration connections.

## Remote Temperature and Humidity Sensors

Temperature and humidity sensors may be ordered for unit mounting in the return air.

## Hot Water Reheat

Where hot water is available, a unit installed reheat coil can use hot water reheat. The coil is designed for 150 psi maximum water pressure and includes a 2-way valve (a 3-way valve is optional).

## Hot Gas Reheat

Unit hot gas discharge is used for reheat and maximum system efficiency.  
(Note: Units with Hot Gas Bypass option are not available with hot gas reheat).

## Unit Mounted Disconnect

A unit mounted nonautomatic disconnect switch is installed in the high voltage electrical section. The operating mechanism allows access to the high voltage electrical components when switched to the "OFF" position. The operating mechanism (handle) protrudes through the decorative door.

## Hot Gas Bypass

A hot gas bypass valve is available for applications that create low suction pressure conditions that could lead to coil freeze and/or compressor cycling. In facilities such conditions generally exist in instances where; 1) a unit's dehumidification mode needs to run for extended period of time; or 2) a room is designed for low entering air conditions; or 3) a unit is utilizing an oversized condenser at low outdoor ambient conditions.

When the system suction pressure is high enough it will maintain pressure on the leaving side of the hot gas bypass valve to keep the valve port closed. Should the suction pressure decrease below the desired setting, the pressure from the suction line forces the diaphragm, which off-sets the spring pressure, allowing the spring to push the valve open. The opening of this valve allows some hot gas to mix with the refrigerant in the suction line raising the evaporator pressure. This increases the suction pressure in the system back to the desired setting. The hot gas bypass can be manually adjusted within a certain range to fine tune the unit to a desired suction pressure in the field.

## 3-Way Water Regulating Valve

3-way water regulating valve for pressure control may be ordered to replace standard 2-way valve installed in water/glycol unit. 3-way valves provide control of condensing temperature maintaining constant system capacity and condenser water flow.

## Condensate Pump

Condensate pumps may be ordered as factory installed or for field installation. Condensate pumps are complete with sump, motor, and automatic control. The pumps are rated for 130 GPH at 20 foot maximum or 40 GPH at 20 feet with check valve. Pumps shipped loose are available in 115, 230, or 460 volt.

## Steam Generator Humidifier

Units may be furnished with an electric steam generator humidifier with "quick change" disposable cylinders and auto-flush cycle. The steam generator humidifier with its patented control system optimizes cylinder life by concentrating incoming water to a predetermined conductivity much higher than that of any entering water. The control system continuously monitors the conductivity in the cylinder through its electronics which allows water to be flushed as often as is necessary to maintain the level at this design conductivity. The high design conductivity results in a minimum flushing of heated water which saves energy. The humidifier is designed to allow all units at any voltage to produce full rated steam output at an optimum low water level. Available in 10 and 30 pound per hour capacities.

## Extended Compressor Warranties

Data Aire offers either a two year or a four year extended compressor warranty in addition to the standard three parts parts warranty. These extended warranties cover parts only - not labor.

# Models & Capacities

DALX-06XX-S @ 2500 CFM						
	Air Cooled		Glycol Cooled		Water Cooled	
EAT °F (DB/WB)	Net Total kW (BTU/hr)	Net Sensible kW (BTU/hr)	Net Total kW (BTU/hr)	Net Sensible kW (BTU/hr)	Net Total kW (BTU/hr)	Net Sensible kW (BTU/hr)
72/58.6	19.0 (64,800)	16.2 (55,500)	18.3 (62,300)	15.9 (54,300)	21.3 (72,800)	17.3 (59,200)
75/61	19.8 (67,700)	16.7 (56,900)	19.2 (65,500)	16.4 (56,000)	22.2 (75,800)	17.7 (60,500)
72/60	19.5 (66,400)	15.3 (52,300)	18.8 (64,100)	15.0 (51,200)	21.9 (74,600)	16.4 (55,900)
75/62.5	20.4 (69,600)	15.7 (53,500)	19.7 (67,300)	15.4 (52,600)	22.8 (77,800)	16.7 (57,000)
80/67	22.0 (75,100)	16.3 (55,700)	21.3 (72,600)	16.0 (54,700)	24.4 (83,300)	17.3 (59,000)

DALX-06XX-S @ 2500 CFM						
	Air Cooled		Glycol Cooled		Water Cooled	
EAT °F (DB/WB)	"Net Total kW (BTU/hr)"	Net Sensible kW (BTU/hr)	Net Total kW (BTU/hr)	Net Sensible kW (BTU/hr)	Net Total kW (BTU/hr)	Net Sensible kW (BTU/hr)
72/58.6	18.6 (63,400)	16.1 (55,100)	18.0 (61,500)	15.6 (53,400)	21.1 (72,000)	17.1 (58,300)
75/61	19.4 (66,300)	16.7 (57,000)	18.8 (64,300)	16.1 (54,800)	22.2 (75,900)	17.6 (59,900)
72/60	19.1 (65,100)	15.2 (52,000)	18.1 (61,700)	14.5 (49,400)	21.5 (73,400)	16.1 (55,000)
75/62.5	20.0 (68,300)	16.3 (53,300)	19.4 (66,300)	15.0 (51,300)	22.8 (77,900)	16.6 (56,600)
80/67	21.5 (73,500)	16.3 (55,500)	21.7 (74,100)	16.0 (54,600)	25.1 (85,500)	17.4 (59,300)

DALX-08XX-S @ 3000 CFM						
	Air Cooled		Glycol Cooled		Water Cooled	
EAT °F (DB/WB)	Net Total kW (BTU/hr)	Net Sensible kW (BTU/hr)	Net Total kW (BTU/hr)	Net Sensible kW (BTU/hr)	Net Total kW (BTU/hr)	Net Sensible kW (BTU/hr)
72/58.6	25.5 (87,000)	21.2 (72,200)	24.7 (84,300)	20.8 (70,900)	28.4 (97,000)	22.5 (76,900)
75/61	27.0 (92,200)	21.8 (74,500)	26.1 (88,900)	21.4 (73,000)	30.0 (102,200)	23.2 (79,100)
72/60	25.8 (88,200)	19.9 (67,800)	25.1 (85,600)	19.5 (66,600)	29.1 (99,400)	21.4 (72,900)
75/62.5	27.6 (94,100)	20.5 (69,900)	26.7 (91,200)	20.1 (68,700)	30.8 (105,100)	22.0 (74,900)
80/67	30.4 (103,800)	21.5 (73,500)	29.5 (100,500)	21.2 (72,300)	22.6 (114,500)	22.9 (78,000)

**DALX-08XX-D @ 3000 CFM**

	Air Cooled		Glycol Cooled		Water Cooled	
EAT °F (DB/WB)	Net Total kW (BTU/hr)	Net Sensible kW (BTU/hr)	Net Total kW (BTU/hr)	Net Sensible kW (BTU/hr)	Net Total kW (BTU/hr)	Net Sensible kW (BTU/hr)
72/58.6	87,000.0	72,600.0	83,000.0	70,200.0	97,100.0	76,900.0
75/61	92,200.0	74,900.0	87,200.0	72,300.0	100,900.0	78,500.0
72/60	88,200.0	68,400.0	84,500.0	66,100.0	99,300.0	72,800.0
75/62.5	94,100.0	69,800.0	89,300.0	68,000.0	104,100.0	74,400.0
80/67	103,800.0	72,800.0	97,600.0	71,500.0	112,000.0	77,000.0

**DALX-10XX-S @ 4000 CFM**

	Air Cooled		Glycol Cooled		Water Cooled	
EAT °F (DB/WB)	Net Total kW (BTU/hr)	Net Sensible kW (BTU/hr)	Net Total kW (BTU/hr)	Net Sensible kW (BTU/hr)	Net Total kW (BTU/hr)	Net Sensible kW (BTU/hr)
72/58.6	31.2 (106,400)	27.1 (92,600)	30.0 (102,400)	26.6 (90,900)	35.4 (120,700)	29.1 (99,200)
75/61	32.7 (111,700)	28.0 (95,400)	31.5 (107,500)	27.4 (93,500)	36.9 (126,000)	29.8 (101,800)
72/60	31.9 (108,900)	25.6 (87,200)	30.5 (103,900)	24.9 (85,000)	36.2 (123,600)	27.5 (93,800)
75/62.5	33.7 (115,000)	26.3 (89,600)	32.3 (110,100)	25.7 (87,600)	37.9 (129,400)	28.1 (95,800)
80/67	36.7 (125,200)	27.5 (93,800)	35.3 (120,600)	27.0 (92,000)	40.8 (139,100)	29.1 (99,300)

**DALX-10XX-D @ 4000 CFM**

	Air Cooled		Glycol Cooled		Water Cooled	
EAT °F (DB/WB)	Net Total kW (BTU/hr)	Net Sensible kW (BTU/hr)	Net Total kW (BTU/hr)	Net Sensible kW (BTU/hr)	Net Total kW (BTU/hr)	Net Sensible kW (BTU/hr)
72/58.6	31.2 (106,400)	26.8 (91,600)	28.6 (97,600)	26.0 (88,700)	33.6 (114,800)	28.3 (96,500)
75/61	32.7 (111,700)	27.8 (94,800)	30.3 (103,500)	26.9 (91,800)	35.4 (120,800)	29.1 (99,300)
72/60	31.9 (108,900)	25.4 (86,600)	29.4 (100,300)	24.4 (83,400)	34.6 (118,000)	26.8 (91,300)
75/62.5	33.7 (115,000)	25.9 (88,500)	31.0 (105,900)	25.1 (85,800)	36.2 (123,600)	27.3 (93,300)
80/67	36.7 (125,200)	26.9 (91,700)	33.8 (115,200)	26.3 (89,900)	38.9 (132,800)	28.4 (96,800)

# Models & Capacities

DALX-13XX-S @ 5000 CFM						
	Air Cooled		Glycol Cooled		Water Cooled	
"EAT °F (DB/WB)"	"Net Total kW (BTU/hr)"	"Net Sensible kW (BTU/hr)"	"Net Total kW (BTU/hr)"	"Net Sensible kW (BTU/hr)"	"Net Total kW (BTU/hr)"	"Net Sensible kW (BTU/hr)"
72/58.6	37.7 (128,800)	32.8 (111,800)	36.2 (123,500)	32.1 (109,400)	42.6 (145,500)	35.0 (119,500)
75/61	39.3 (134,200)	33.6 (114,600)	38.2 (130,400)	33.1 (112,900)	44.7 (152,500)	36.0 (122,700)
72/60	38.0 (129,800)	30.5 (104,100)	36.9 (125,900)	30.0 (102,400)	43.7 (149,100)	33.0 (112,700)
75/62.5	40.4 (137,900)	31.5 (107,400)	39.2 (133,800)	30.9 (105,600)	46.0 (156,800)	33.8 (115,500)
80/67	44.4 (151,400)	33.1 (112,800)	43.0 (146,800)	32.6 (111,100)	49.6 (169,400)	35.2 (120,100)

DALX-13XX-D @ 5000 CFM						
	Air Cooled		Glycol Cooled		Water Cooled	
"EAT °F (DB/WB)"	"Net Total kW (BTU/hr)"	"Net Sensible kW (BTU/hr)"	"Net Total kW (BTU/hr)"	"Net Sensible kW (BTU/hr)"	"Net Total kW (BTU/hr)"	"Net Sensible kW (BTU/hr)"
72/58.6	37.7 (128,800)	33.0 (112,700)	36.1 (123,100)	32.0 (109,200)	42.4 (144,600)	34.9 (119,100)
75/61	39.3 (134,200)	34.2 (116,800)	38.0 (129,800)	33.0 (112,700)	44.3 (151,000)	35.8 (122,000)
72/60	38.0 (129,800)	30.9 (105,600)	37.2 (126,800)	30.1 (102,700)	43.4 (148,200)	32.9 (112,200)
75/62.5	40.4 (137,900)	31.8 (108,400)	39.2 (133,600)	30.9 (105,500)	45.4 (155,000)	33.6 (114,800)
80/67	44.4 (151,400)	33.1 (113,000)	42.4 (144,700)	32.3 (110,300)	48.8 (166,400)	34.8 (118,900)

DALC-06XX thru DALC-08XX						
	"DALC-06XX @ 2,500 CFM, 14 GPM"		"DALC-08XX @ 3,000 CFM, 16 GPM"		-	
"EAT °F (DB/WB)"	"Net Total kW (BTU/hr)"	"Net Sensible kW (BTU/hr)"	"Net Total kW (BTU/hr)"	"Net Sensible kW (BTU/hr)"	"Net Total kW (BTU/hr)"	"Net Sensible kW (BTU/hr)"
72/58.6	14.8 (50,500)	14.4 (49,200)	19.9 (68,000)	19.0 (64,800)	-	-
75/61	17.2 (58,800)	15.8 (53,800)	23.2 (79,200)	20.7 (70,600)	-	-
72/60	15.6 (53,300)	13.9 (47,300)	21.1 (72,100)	18.3 (62,300)	-	-
75/62.5	18.4 (62,700)	15.1 (51,600)	24.8 (84,700)	19.8 (67,700)	-	-
80/67	23.7 (80,900)	16.9 (57,800)	31.9 (108,700)	22.2 (75,900)	-	-

<b>DALC-10XX thru DALC-13XX</b>						
	<b>"DALC-10XX @ 4,000 CFM, 17 GPM"</b>		<b>"DALC-13XX @ 5,000 CFM, 20 GPM"</b>			
<b>"EAT °F (DB/WB)"</b>	<b>"Net Total kW (BTU/hr)"</b>	<b>"Net Sensible kW (BTU/hr)"</b>	<b>"Net Total kW (BTU/hr)"</b>	<b>"Net Sensible kW (BTU/hr)"</b>	<b>"Net Total kW (BTU/hr)"</b>	<b>"Net Sensible kW (BTU/hr)"</b>
72/58.6	26.0 (88,700)	25.0 (85,200)	30.1 (102,600)	29.2 (99,600)	-	-
75/61	30.1 (102,600)	27.1 (92,600)	34.8 (118,700)	31.9 (108,700)	-	-
72/60	27.3 (93,000)	23.9 (81,400)	31.4 (107,100)	27.9 (95,200)	-	-
75/62.5	31.8 (108,400)	25.9 (88,300)	36.6 (125,000)	30.3 (103,300)	-	-
80/67	40.3 (137,600)	28.7 (98,000)	46.6 (158,900)	33.6 (114,800)	-	-

<b>DALX-XXXXX @ STANDARD AIRFLOW</b>					
	<b>Belt Driven Fan</b>		<b>Dimensions</b>		
<b>"Capacity, Tons"</b>	<b>Standard Blower Size</b>	<b>Standard Fan Motor, HP</b>	<b>"Depth, in."</b>	<b>"Length, in."</b>	<b>"Height, in."</b>
6	15 x 9 R	2	48.0	72.0	29.5
8	15 x 9 R	2	48.0	72.0	29.5
10	15 x 9 R	3	48.0	72.0	29.5
13	15 x 9 R	5	48.0	72.0	29.5

1. Performance data is based on ACFM and tested in compliance with ASHRAE Standard 127-2007 Standard Rating Conditions.
2. DOE certification reports and compliance statements for Data Aire products can be found under The Compliance Certification Database at <https://www.regulations.doe.gov/certification-data/>
3. Net capacity data includes fan motor heat.
4. Models with an AO suffix are configurations with the compressor located in outdoor condensing unit.
5. Consult factory for alternate operating conditions or options as these may impact unit performance.

www.DataAire.com  
800-347-2473 | sales@DataAire.com  
230 W. Blueridge Avenue  
Orange, CA 92865



A member of the  
C/S Group of Companies  
Making Building Better®